

DUPLI-CARVER®

**MODEL
T110A**

**SPINDLE CARVER OPTION
ASSEMBLY/ALIGNMENT INSTRUCTIONS
JUNE 2003**

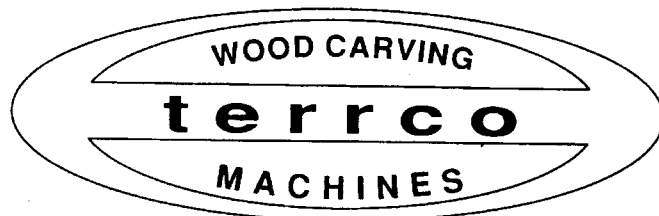
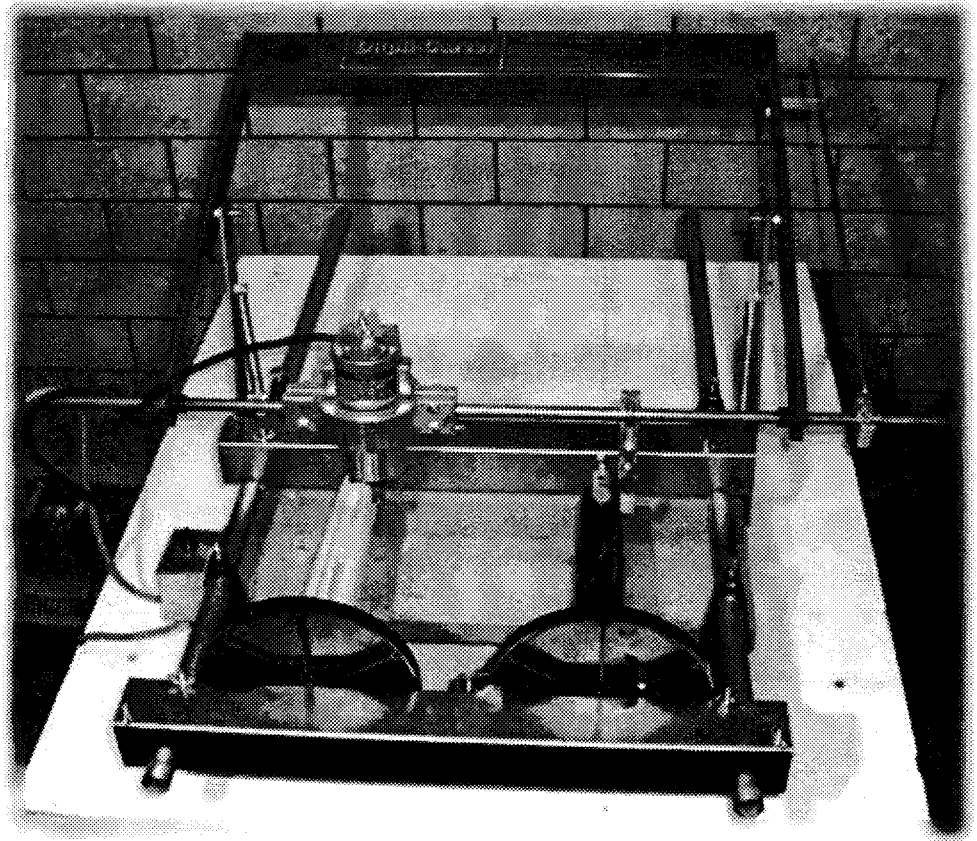

terrco, inc.

222 First Avenue N.W. • Watertown, SD 57201

Phone: 605-882-3888 • Fax: 605-882-0778

Email: info@terrco.com • Website: www.terrco.com

T110A SPINDLE CARVER ASSEMBLY INSTRUCTIONS

PARTS LIST

<u>ITEM</u>	<u>QTY</u>	<u>PART#</u>	<u>DESCRIPTION</u>
1.	(2)	SO6276	CARRIAGE TUBES
2.	(2)	MO6287	CARRIAGE ARMS
3.	(2)	MO6285	8" DIAMETER BLACK PLASTIC TURNTABLES
4.	(1)	AO6279	BAG ASSEMBLY
a.	(2)	SO6280-1	BALL CENTERS
b.	(2)	SO6281	1/2" OD X 1/4" ID X 1" LONG BUSHINGS
c.	(2)	SO6247	1/4" DIAMETER DRIVE PINS
d.	(1)	SO6282	TURNTABLE LOCK BRACKET
e.	(4)	FO5005-12	1/4-20 X 2 1/4 U BOLTS
f.	(2)	FO5005-1	1/4-20 X 3/4 HEX HEAD BOLTS
g.	(2)	FO5005-5	1/4-20 X 1 1/2" HEX HEAD BOLTS
h.	(1)	FO5005-3	1/4-20 X 1 1/4" HX HEAD BOLT (FULL THREAD)
i.	(4)	FO5005-14	1/4-20 THUMB SCREWS
j.	(4)	FO5010-18	1/4-20 SQUARE NUTS
k.	(3)	FO5010-9	1/4-20 KEPS NUTS
l.	(9)	FO5010-13	1/4-20 WING NUTS
m.	(1)	MO6395	T110A ASSEMBLY MANUAL

ASSEMBLY INSTRUCTIONS FOR THE T110A SPINDLE CARVER

1. The Spindle Carver is used as an attachment for the T110 Dupli-Carver® machine. The carving machine must be completely assembled and aligned prior to adding the attachment.
2. Remove the two turntables from the table top of the T110.
3. Once the Spindle Carver is attached, the router bit and stylus will not reach the table top. At this time, install a 1/4" round bottom router bit in the router and a 1/4" round bottom stylus in the stylus holder. Use the table top to adjust the bit and stylus to equal lengths, by touching their tips to the table top and adjusting the stylus in its holder. (Note: If re-checking of bit and stylus is required after the Spindle Carver is attached, equal height spacers such as pop cans, soup cans or two equal wood blocks can be used.)

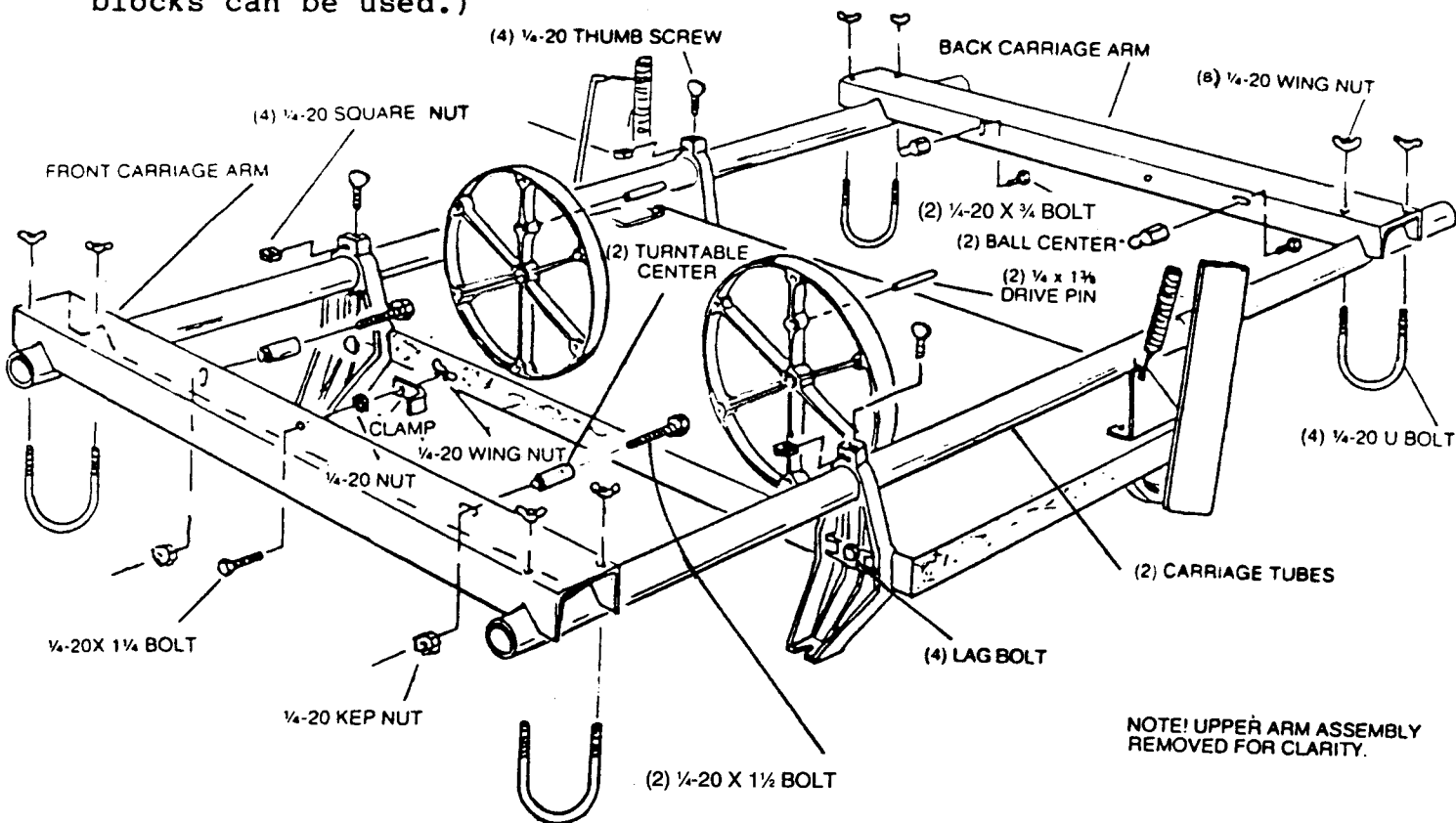

4. Loosen the lag bolt securing the table legs to the table top.
5. Slide a carriage tube into the holes at the top of the legs on each side of the machine.
6. Attach one of the carriage arms near the end of the carriage tubes at the front of the machine using two 1/4-20 U-bolts and wing nuts, finger tight. Be sure that the two slotted holes on the face of the carriage arm are toward the table top.

7. In a similar manner, install the second carriage arm at the other end of the carriage tubes. Again, the two slotted holes on the face of the carriage arm should be toward the table top.
8. Install a 1/4-20 square nut and 1/4-20 thumb screw in each leg, but do not tighten against tubes yet.
9. Tighten by hand the wing nuts on the U-bolts on the front carriage arm, then hand tighten the rear carriage arm U-bolt wing nuts.
10. Slide the carriage through the holes of the table legs. When the carriage appears to slide front to rear and rear to front smoothly, wrench tighten the four bolts holding the legs to the table top.
11. In the front carriage arm, install the front center bushings in the slotted holes, using a 1/4-20 X 1 1/2" hex head bolt and 1/4-20 Keps nut. The nut goes inside the carriage arm, finger tight.
12. In the rear carriage arm, install the rear ball centers in the slotted holes, using a 1/4-20 X 3/4" hex head bolt from inside the carriage arm, finger tight.
13. Slide the entire carriage until the front carriage arm is against the front legs. Tighten the four thumb screws.
14. Using the router bit and stylus set-up, align the front center bushings horizontally so that their span is the same as the router bit and stylus span. Also, align vertically until both bushings touch the tip of the router bit and stylus. See Figure 2A and 2B.

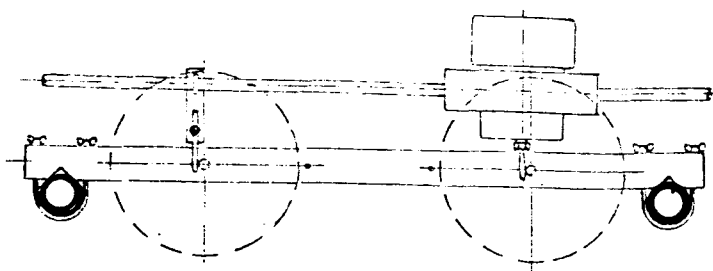

FIGURE 2A

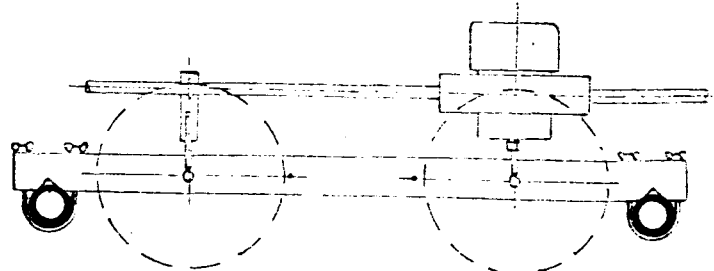

FIGURE 2B

Securely wrench tighten the nuts to lock the bushing positions. Re-check after tightening to validate alignment.

15. Loosen the four thumb screws and slide the carriage until the rear carriage arm is against the back legs. Re-tighten the thumb screws.
16. In a manner similar to the front center bushings, align the ball portion of the rear ball centers and tighten the bolts when aligned. Re-check after tightening.
17. This completes the aligning of the Spindle Carver.
18. Slide the black plastic turntables onto the front center bushings. The flat face of the turntable should be toward the table top.
19. Install the 1/4-20 X 1 1/4 hex head bolt into the front carriage arm from inside the arm. Secure with a 1/4-20 Keps nut.
20. Slide a turntable lock bracket onto the bolt and secure with a 1/4-20 wing nut. Tightening the wing nut will lock the turntables and prevent rotation.
21. Use the position arm from the T110 carving machine in the peripheral holes of the plastic turntables to cause the turntables to rotate in unison. Always have a position arm in place and clamp the turntables before carving

This completes the assembly and alignment of the Spindle Carver attachment.

The spindle carving attachment can be removed as a U-shaped unit by removing the rear carriage arm, loosening the thumb screws and sliding the unit to the front of the machine.

Refer to the following "Spindle Carving Operating Instruction" for carving with the Spindle Carver.

**GENERAL CARVING INSTRUCTIONS
FOR THE T110A SPINDLE CARVER**

The Spindle Carver attachment allows the standard T110 Dupli-Carver® to carve objects of much greater length (height) than can be achieved in vertical carving.

The pattern and wood are attached to the Spindle Carver turntables in the horizontal position, and the length is carved a section at a time (carving the full 360 degrees of each section). When each increment or section is finished, index to the next section by sliding the spindle carriage to the next section. The most common type of objects carved using the Spindle Carver are gun stocks, table legs, long lamp bases, tall statuary or any spindle item which falls within the size capabilities of the model owned.

The mounting provisions are very basic due to the many variables in items to be carved. The objects are mounted like lathe pieces with two locating pins on the front turntables (a 1/2" bushing used as a pivot center and a 1/4" pin as an indexing driver). The rear cross arm has 1/2" ball centers. The turntables are indexed with a positioning arm, allowing you to carve the full 360 degrees of each section accurately.

OPERATING INSTRUCTIONS

To Operate:

1. Mount the 8" turntables provided to the front carriage arm with the drive pins on the turntables pointed forward (away from you). Orient turntables with the positioning arm of the Dupli-Carver.
2. The master and duplicate are mounted to the carriage assembly by supporting them between the ball centers of the back carriage arm and the 1/2" and 1/4" drivers of the front carriage arm. Adapter blocks on both ends of master and duplicate are required in many instances to provide the drilled holes necessary for mounting. Due to the broad variety of shapes, etc. the user will have to develop the necessary adaptation. (See sample picture below)
3. Slide the back carriage arm toward the front carriage arm until master wood to be duplicated are suspended tightly between centers, then tighten into place.
4. The positioning arm allows rotation in unison of the objects through 360 degrees and a lock is provided on the front carriage arm to maintain any given angular position.
5. With the Spindle Carver in place, the router and stylus can no longer touch the table top for depth adjustments. The two router wrenches (being of the same length) can be stood between the table top and stylus/bit and so used as gauges for the depth adjustment. Or, if preferred, two wood blocks of equal length, two pop cans, soup cans, etc. can be used for that same purpose.
6. BE SURE TO TIGHTEN BIT AND STYLUS. CHECK FREQUENTLY. A CREEPING BIT OR STYLUS CAN RUIN YOUR CARVING.
7. For general spindle carvings, the instructions from this point are the same as those listed in the standard operating manual.

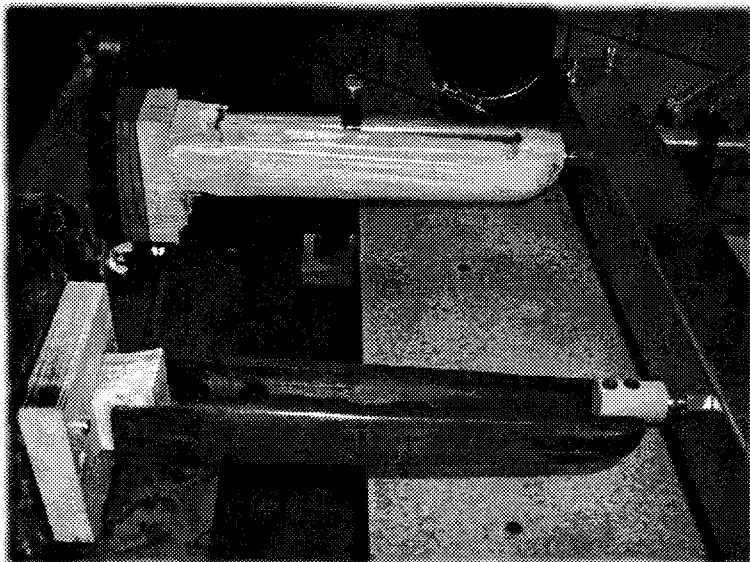

GUNSTOCK CARVING TIPS

Carving a gunstock is a relatively simple task on the Dupli-Carver[®] using the Spindle Carver, ESPECIALLY when you have read and follow these 'tips' for trouble free carving. We also suggest you make your first stock a practice carving. Do not use that special piece of wood until you have experienced the application of the instructions given.

Read the following tips carefully:

ALWAYS keep the router bit bottomed in the chuck and tight at all times. Check often.

ALWAYS keep the stylus tight and check its setting in relationship to the bit. Any 'creep' of the bit OR stylus will cause too deep a cut because the bit will always creep down or out, while the stylus will creep up. This will ruin your carving.

ALWAYS add several layers of scotch tape around the outer diameter of the stylus tips when using a matching stylus and bit during the finishing step. This will compensate for vibration and router chuck run-out. Tape can be removed one layer at a time to get exact sizing. REMEMBER: You can always remove more wood from the stock, but you can never add wood.

ALWAYS rough the entire stock before you do any finish carving. Be very careful around any inletting or the barrel channel.

ALWAYS gauge the barrel groove and cut-outs after the first cuts with the tape wrapped stylus. If additional wood needs to be removed, unwrap layers of tape from the stylus and recarve until the proper size is reached.

ALWAYS keep the turntable positioning arm IN PLACE in the turntables at all times.

BIT AND STYLUS TIP SIZES RECOMMENDED FOR GUNSTOCK CARVING

Shape	Part Bit	Number Stylus	Use
1/8" Flat	102	302	Lock cutouts, Tangs
1/4" Flat	103	303	Cutouts, Tangs, Octagon Barrel Channels
1/2" Round	104	304	Round Barrel Channels
1/2" Flat	105	305	Shaping the Stock Itself
3/4" Round	106	306	Round Barrel Channel
3/4" Flat	---	308	For Roughing with #105 Bit

TO MOUNT THE ORIGINAL

Cut a block of wood shaped to mate with the butt of the stock and fasten with wood screws. This will give you a flat surface to locate the 1/2" and 1/4" drive pin holes (use turntable as a template).

Shape and place a small wood block into the end of the barrel channel and secure it with the hose clamp. Drill a 1/2" diameter by 1/2" deep hole in the end of the block to mate with the ball center.

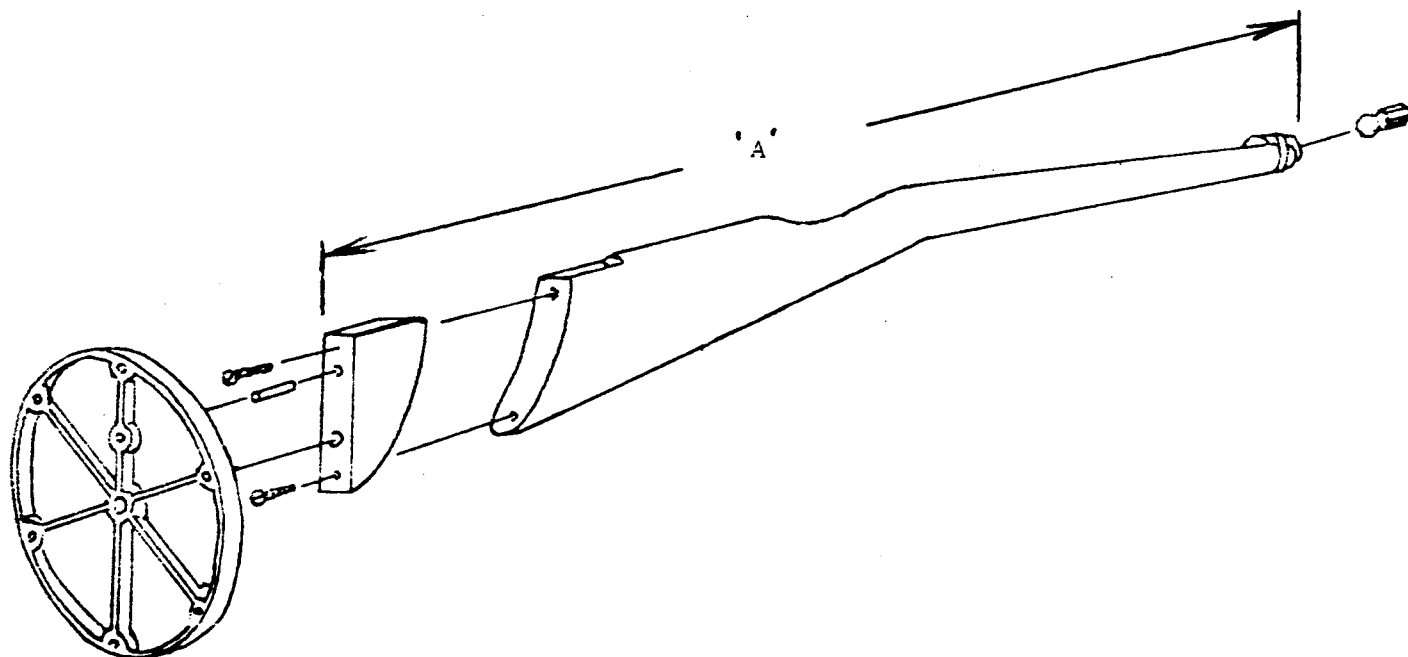

TO MOUNT THE BLANK

Cut blank to the total length of the original (including mounting blocks, see 'A' in above diagram). Mark and drill the 1/2" diameter by 1/2" deep ball center hole in the barrel end. To locate the holes in the butt end of the stock, mount the original in the right hand side loosely and the ball end of the blank in the left hand, wedging the butt against the 1/2" center. Use the router bit and stylus as a gauge to mark the location of the butt. Proper location is achieved when the router bit makes contact with the blank over the entire stock without the stylus touching the original stock. Mark the turntable (with pencil or tape) and drill the 1/2" center hole. The stocks can be clamped securely and the 1/4" driver hole can be drilled and pin installed while on the machine.

It is our recommendation that the entire gunstock be roughed to shape before any final carving is done. To do this, use the 1/2" flat bit (Part #105) and the 3/4" flat stylus (Part #308) and set the stylus approximately 1/4" to 1/8" deeper than the bit. Carve the entire stock including the inletting you can reach, and barrel channel at this setting.

When this is done, your stock should be roughed within 1/4" of the original and your finishing can now start. The barrel channel inletting should be done first. The 1/2" round bit and stylus (Parts #104 and #304) should be used for a round barrel (a 3/4" round bit and stylus is also available).

In cutting the barrel groove, wrap the stylus with several layers of scotch tape (see diagram) and also set the stylus depth as much as 1/16" deeper than the bit. This will compensate for any wood vibration and deflection as well as error generated by router collet run-out.

Gauge the groove size and if more wood needs to be removed, take off a layer of tape, adjust the stylus depth closer to the bit and go over the groove again. Then re-gauge.

To carve an octagon barrel groove, use the 1/4" flat bit and stylus (parts # 103,#303) again wrapping the stylus with tape and setting it 1/16" deeper. To shape the octagon, cut in the bottom flat first with stock upright, then rotate stock 45 degrees and cut next flat and rotate 45 degrees in the opposite direction to cut the other flat. Rotate the stock back to vertical and cut the two sides.

Again, gauge the groove with the barrel itself. If more wood needs to be cut away, remove a layer of tape and adjust the stylus depth closer to the bit and go over the groove again, then gauge again. Repeat until the fit of the barrel in the channel is proper.

The next step in carving is shaping the stock itself. Use the 1/2" flat bit and stylus (Parts #105,#305) and again wrap with tape. Best results are obtained by keeping the flat bottom against the stock at all times, drawing the stylus and bit along the stock in a parallel plane very similar to the way a draw knife is used. DO NOT cut with the side or outside edge of the bit.

The last areas to be carved are the lock and trigger cutouts. Use the 1/4" flat bit and stylus (wrapped with tape to leave extra wood) to make your first cuts. Care should be taken in this step because you want to leave enough wood to clean up with the next bit. The 1/8" flat bit and stylus are then used to do the final inletting.

